Comfort-Aire®

Century®

REPLACEMENT PARTS LIST

**Single Zone Low Temperature
Ductless Mini-Split**

A-VMH18SU-1A

EXPLODED VIEW

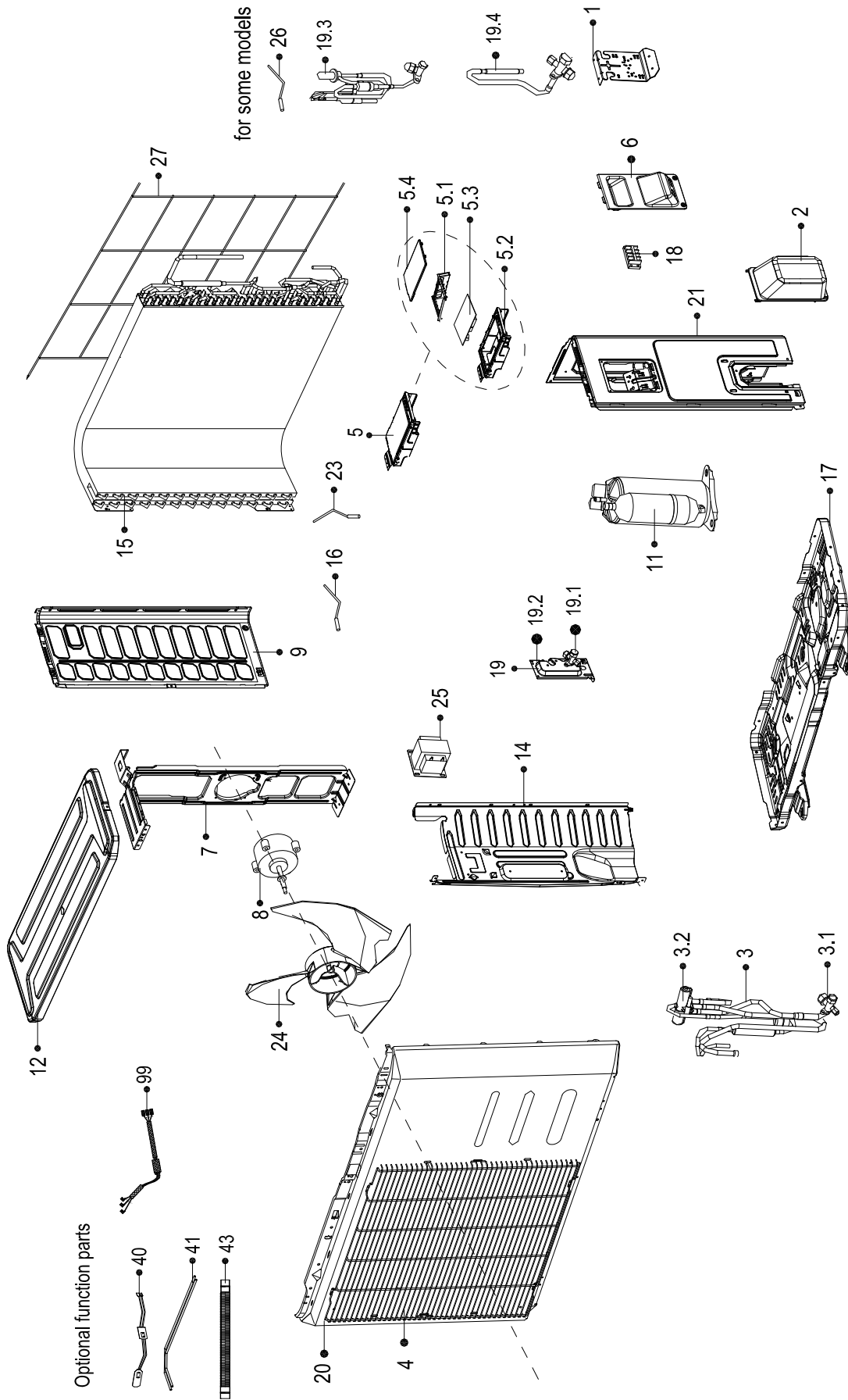

REPLACEMENT PARTS

Location	Part Name	Quantity	Part No.
1	Terminal instalation subassembly		12222000004782
2	Water collector		12122000007150
3	4-way valve assembly		15422000004795
3.1	Gas valve		15500204000046
3.2	4-way Valve		15500216000026
4	Air outlet grille		12222000007425
5	Electronic control box subassembly		17222000009213
5.1	Support of electronic control box		12122000014683
5.2	Electronic installing box subassembly		12222000004827
5.3	Outdoor main control board subassembly		17122000018581
5.3.1	Electronic installing box subassembly		12122000006856
6	Big handle assembly		12222000005102
7	Supporter subassembly of fan motor		12222000004884
8	Brushless DC Motor		11002015000397
9	Left side plate assembly of cabinet		12222000004831
11	DC Inverter Rotary Compressor		11103020000179
12	Top cover assembly		12222000004835
14	Partition board assembly		12222000004784
15	Condenser assembly		15822000008240
16	Room Temperature Sensor		11201007002020
17	Chassis assembly		12222000004824
18	Terminal		17400401000075
19	Liquid valve assembly		15422000004796
19.1	Liquid valve		15500208000028
19.2	Valve plate		12222000002571
19.3	Electronic expansion valve		15500213000178
20	Front panel assembly		12222000006304
21	Right side plate		12222000004830
23	Pipe Temperature Sensor		11201007000069
24	Axial flow fan		12100105000181
25	Reactor		17400306000058
26	Discharge Temperature Sensor		11201007000005
27	Rear net		12222000004833
40	Crankcase electric heater		17402001000119
41	Electric heating tube (pan heater)		17402002000043
43	Drain pipe		12100509000059
99	Compressor wire subassembly		174012030000939

Due to ongoing product improvements, specifications and dimensions are subject to change and correction without notice or incurring obligations. Determining the application and suitability for use of any product is the responsibility of the installer. Additionally, the installer is responsible for verifying dimensional data on the actual product prior to beginning any installation preparations.

Incentive and rebate programs have precise requirements as to product performance and certification. All products meet applicable regulations in effect on date of manufacture; however, certifications are not necessarily granted for the life of a product. Therefore, it is the responsibility of the applicant to determine whether a specific model qualifies for these incentive/rebate programs.

Comfort-Aire®  **Century**®